

Technical Specifications

Airflow and Performance

- Airflow Capacity:** 0.5 m³/s to 4.0 m³/s
- Odour Dwell Time:** 0.2 seconds or greater
- Grease and Particulate Removal:** High-efficiency filtration systems

Electrical Requirements

- Power Supply:** [Specify Voltage, e.g., 220V/50Hz]
- Control Systems:** Advanced controls with user-friendly interfaces

Dimensions

- Modular Sizes:** Configurable to fit various space requirements
- Weight:** 350 kg - 1500 kg



Installation and Maintenance

- Easy Installation:** Modular design simplifies the installation process.
- Maintenance Access:** Convenient access panels for quick filter changes and servicing.
- Longer Filter Lifespan:** Reduces downtime and operational costs.

Applications

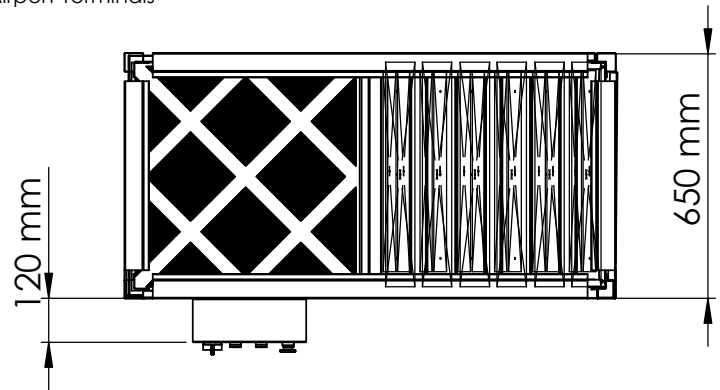
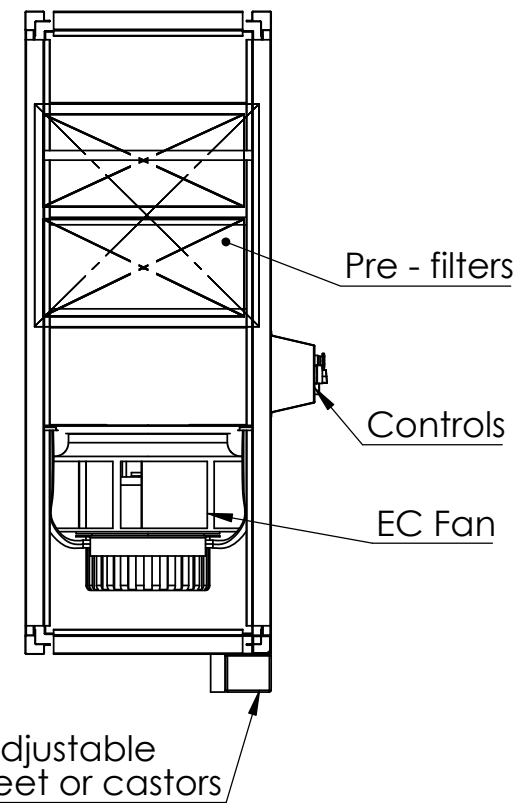
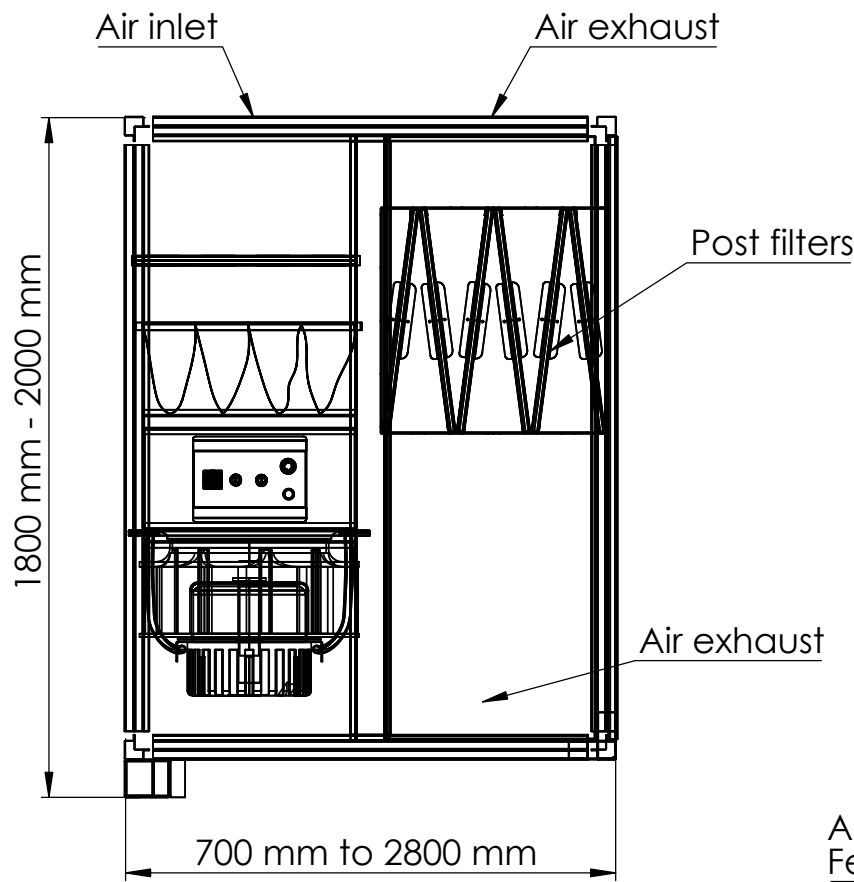
- Restaurants and Cafés
- Fast Food Chains
- Commercial Kitchens
- Architectural Projects
- Heritage and Listed Buildings
- Basement Installations
- Airport Terminals



T: 0330 350 1101 E: info@3343.co.uk		TITLE:	
  		DWG NO.	A4
		2024-9-22-ReLine	
SCALE:1:50		SHEET 1 OF 1	